



## The **LEITNER CPS**

Maximum safety and availability

**Basis** The new CPS (Cable Position Supervision) system is the advancement of a proven proximity switch for the monitoring of the cable position, which LEITNER has applied in North America for many years.

**Description** The CPS consists of a central evaluation unit in the drive station and inductive-type proximity switches on the towers. For each roller battery, only two sensors are applied. These are installed at the first and last rocker of each roller battery.

When the sensors detect an incorrect position of the cable, they send a signal to the evaluation unit. Consequently, the main control immediately initiates the appropriate safety measure (slowing down or stop), depending on the state of the cable.

The evaluation unit and the proximity switches are connected via a state-of-the-art safety bus system. Stop buttons on the towers and the brake forks can also be connected to the bus system. The voltage supply on the towers is provided via an additional supply cable.

The CPS can also be applied to compression towers. The full scope of the monitoring functions can be achieved by installing additional pressure rollers.

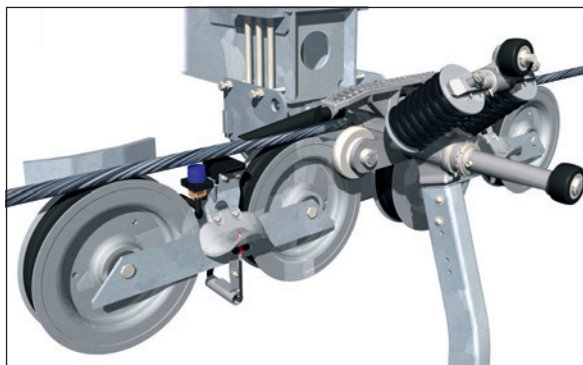

**Benefits** With regard to the cable position, the LEITNER CPS ensures the **highest level of safety and availability** of the installation. As soon as the cable leaves the groove of the roller, it is reliably corrected with the help of the CPS.

The application of the safety bus system requires **minimal wiring**. Moreover, the safety bus system detects malfunctions of all individual sensors, allows a **selective bypass** of all sensors and therefore **reduces the required replacement measures** to a minimum.

## Technical data

Voltage supply	230V AC for central evaluation unit 120V DC for tower equipment
Signal transfer	Safety bus/diagnosis bus
Monitoring functions	Cable out of position (level 1) countermeasure: slowing down Cable out of position (level 2) countermeasure: stop Cable too close to sensor countermeasure: stop
Requirement class	AK4 (fail-safe) – for monitoring of level 2 AK2 – for monitoring of level 1 and “cable too close to sensor”